

tubiq

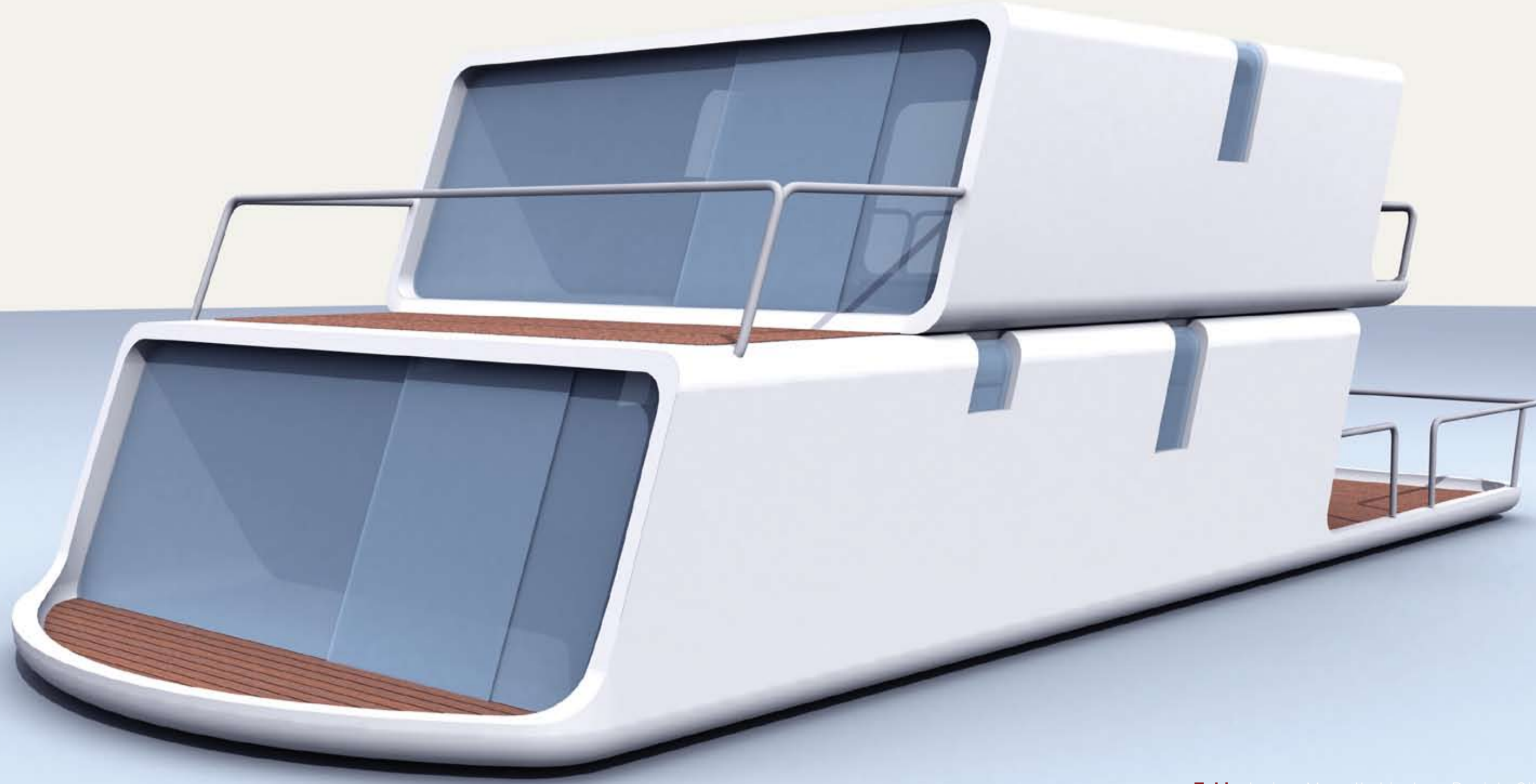

Tubiq design: Marcello Ligabue, Daniele Gibertoni

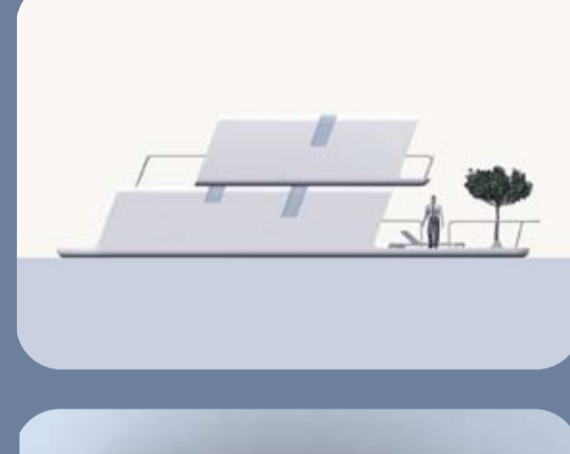
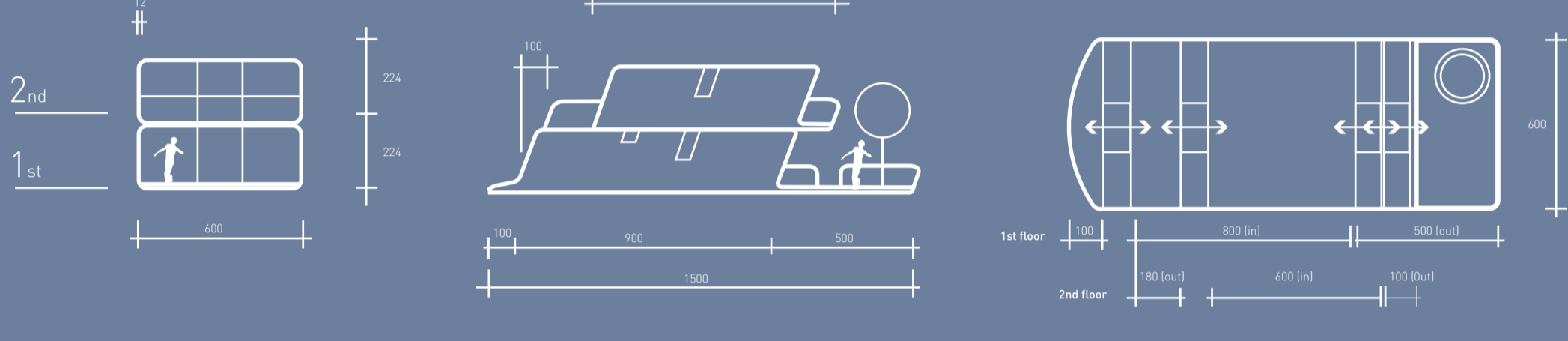
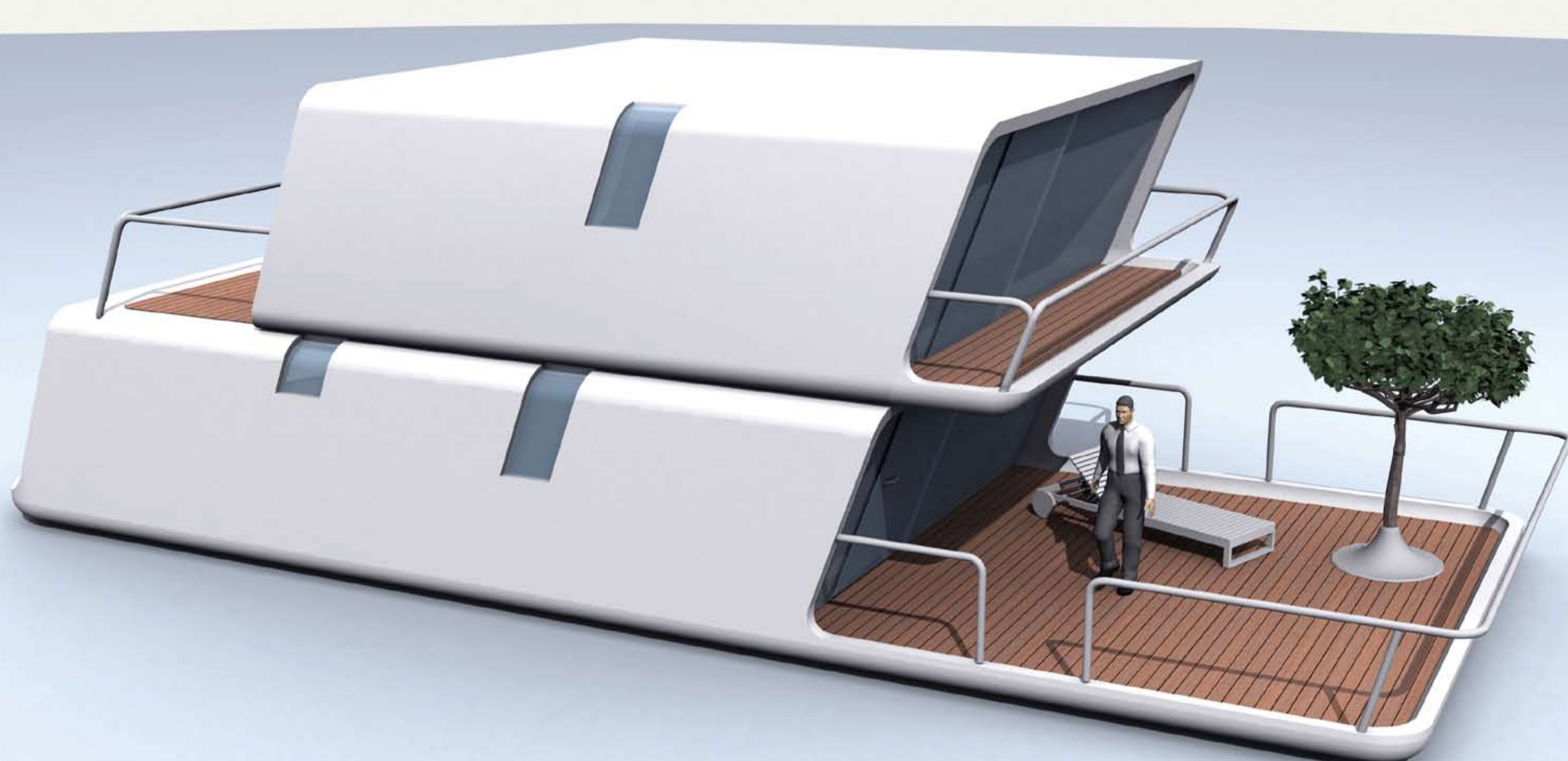

TUBIQ: LA NUOVA ERA DELLA CACQUA

Concetto abitativo e nautico si fondono in Tubiq.

Una struttura che conserva il dinamismo e l'eleganza di un'imbarcazione ma che è a tutti gli effetti un raffinato spazio abitativo su 2 livelli con tutti i confort di un abitazione moderna.

Un'abitazione che si estende su una superficie di circa 150mq di cui 90mq coperti distribuiti su 2 livelli, 30mq di giardino outdoor e 30mq di terrazzi.

Un progetto che guarda al futuro, un mix di modernità e raffinatezza pensati per un nuovo modo di concepire il benessere abitativo.

4

INTERIORS

5



6



# VILLA

20m



VARIANTI

7



1°PIANO: Sup. Coperta = 70 mq | Sup. Outdoor = 46 mq

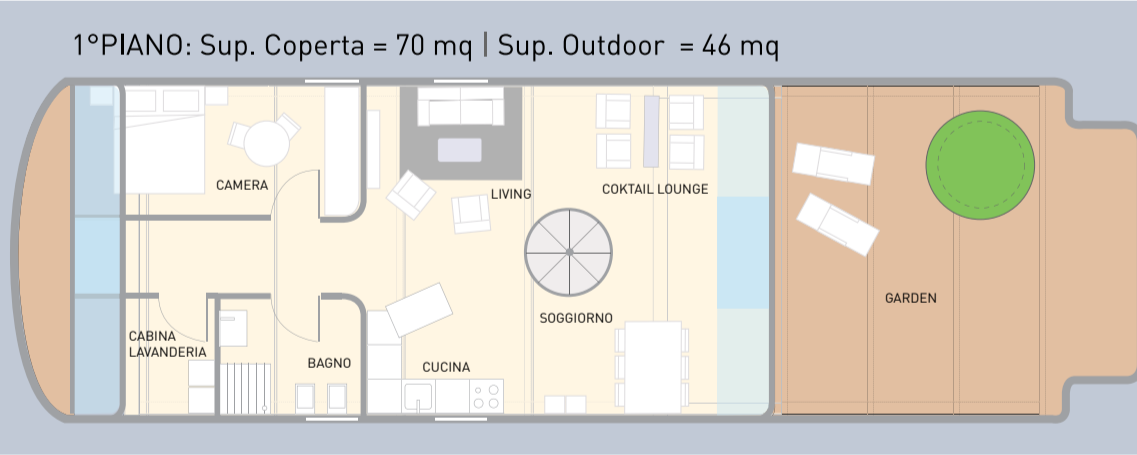

1st

2°PIANO: Sup. Coperta = 54 mq | Sup. Outdoor = 20 mq

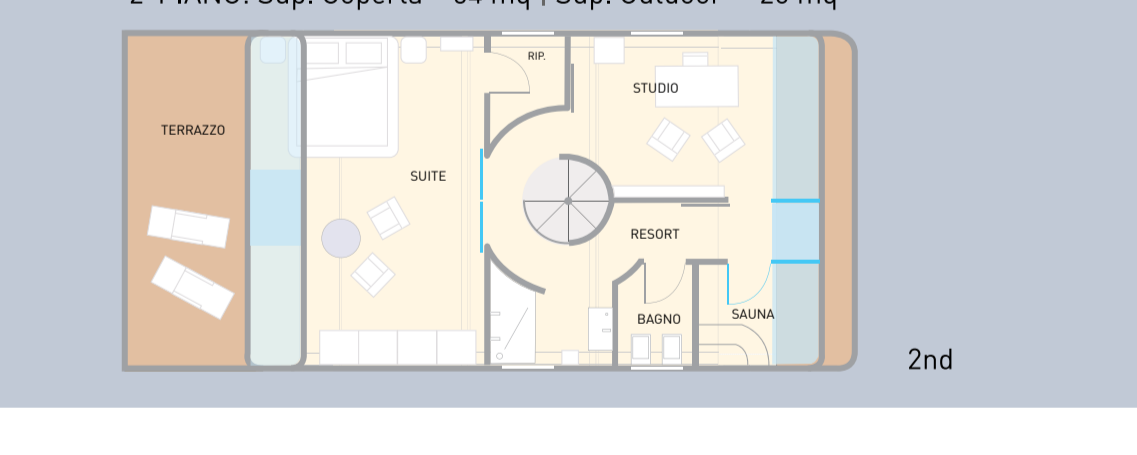

2nd

# LOFT

15m

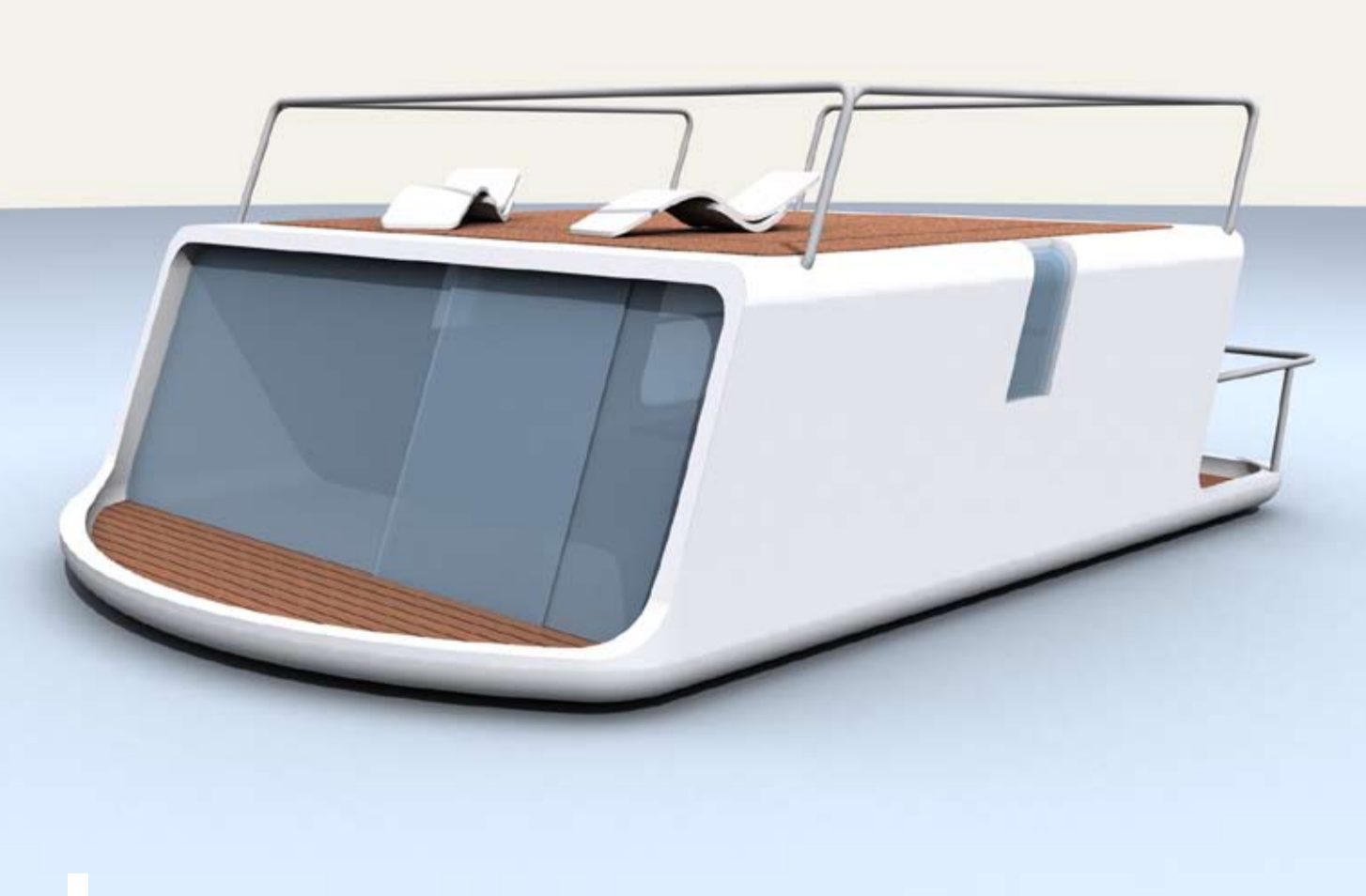

8



1°PIANO: Sup. Coperta = 55 mq | Sup. Outdoor = 22 mq

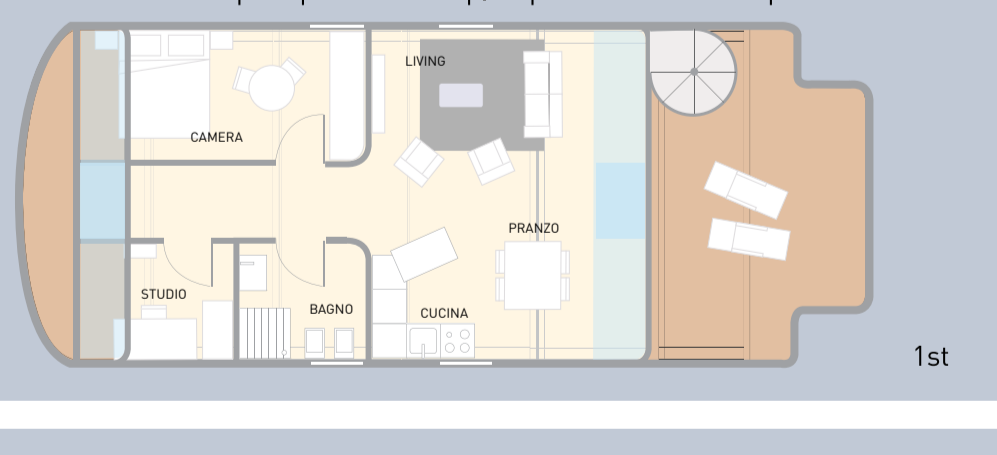

1st

TERRAZZO: Sup. Outdoor = 55 mq

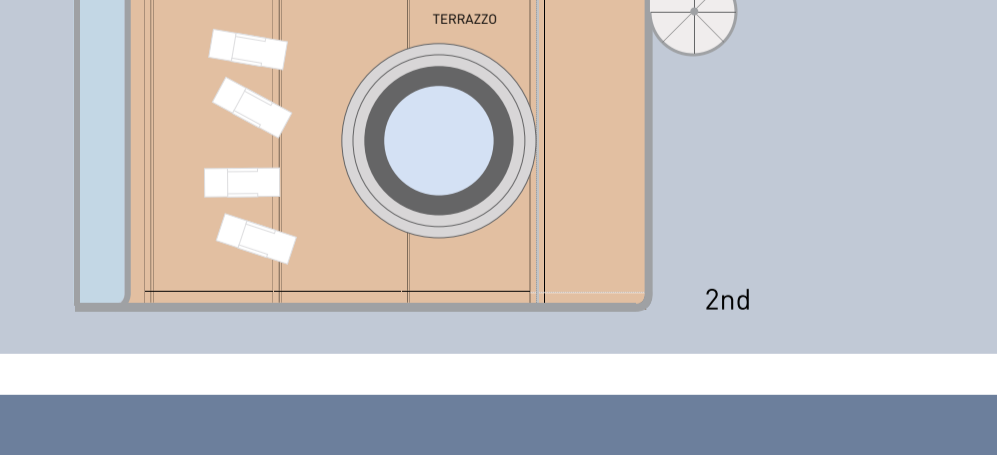

2nd

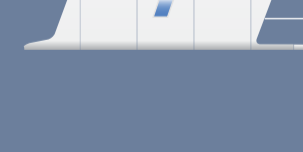

LOFT

lunghezza = 10mt  
coperti = 36mq  
scoperti = 42mq

VILLA

lunghezza = 15mt  
coperti = 84mq  
scoperti = 42mq

FORESTERIA

lunghezza = 21mt  
coperti = 156mq  
scoperti = 84mq

HOTEL

lunghezza = 40mt  
coperti = 524mq  
scoperti = 420mq

MODULARITA' PER UN'INFINITA' GAMMA DI SOLUZIONI

9

tubiq

produzione e commercializzazione



Teknotat Marine Srl  
via della Conca 3, 26100 Cremona, Italia.

tel + 39 0372 800225  
fax + 39 0372 800087

www.teknotatmarine.it

design and communication

marcello ligabue  
www.designwerkstatt.it